

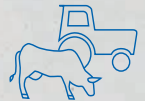

EISELE

Knowledge in motion



Agriculture



Biogas



Biogas Ex

Long axis agitators ESR

The long axis agitator ESR 204 features a 15 kW electric motor (authorised for explosion protection zone 2), and with its maximum speed of 100 rpm and a propeller diameter of 140 cm, it provides top thrust and optimal mixing results in biogas plants.

With a shaft length of 450 cm, it can be adjusted to different tank sizes. The angle is adjusted either mechanically or hydraulically.



15.0 kW

Benefits

- High mixing performance with optimised propeller
- Low maintenance
- Long service life
- Base plate and mounting frame in acid-resistant stainless steel as a standard
- Fast, easy assembly

Long axis agitators ESR

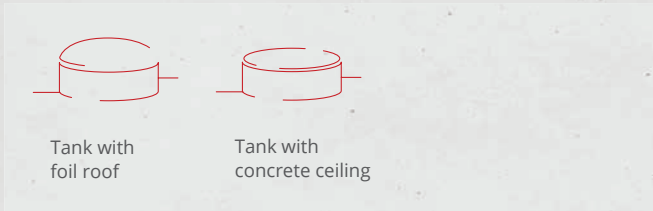

Features

- Base plate and mounting frame in acid-resistant stainless steel
- Spur gear motor
- Three-blade propeller
- Mechanical seal on motor and medium side
- Approved for explosion protection zone 2

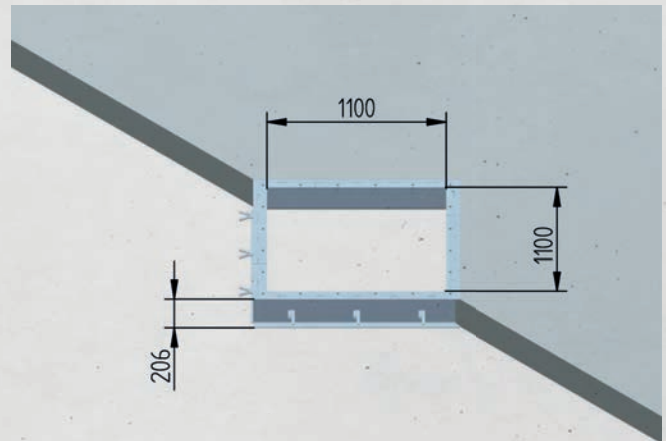

Illustration: measurements of mounting frame for ceiling installation

Technical Data

Type	PROPELLER DATA			MOTOR DATA			
	Propeller Ø	Speed	Thrust	Rated power		Speed	Rated current
ESR	mm	rpm	N	kW	hp	rpm	A
204	1,400	100	5,200	15.0	20.0	1,460	29.4

Performance data are related to water. Specifications and illustrations are non-binding.